

RENOLD



RB Flexible Coupling

[Brochure](#)

RENOLD | Couplings

Contents

Renold Couplings	3
RB Flexible Coupling	4
RB Typical Applications	5
RB Shaft to shaft	6
RB Shaft to shaft with increase shaft engagement	7
RB standard SAE flywheel to shaft	8-9
RB standard SAE flywheel to shaft with increased shaft engagement	10-11
Technical Data	12-14
Design Variations	15
Global services	16



Innovation Everyday

Renold have been driving industry forward through innovation since 1879. Renold Couplings drives industry the world over, from marine, cranes and hoists to manufacture, mass transportation and the pulp and paper industry. Our couplings connect machines to machines through stock solutions and bespoke-crafted connections, all manufactured in our high-tech engineering factories.

Engineering capability

A team of in-house design engineers work to continuously improve the existing product range, introduce new products and deliver innovative new solutions to our customers challenges.

British manufacturer

Since 1946 Renold Couplings have manufactured a full range of couplings and clutches.

Based in Cardiff, UK, we control the full design and manufacture process, bringing class leading quality and complete customer peace of mind.

Worldwide support

With manufacturing facilities in 4 continents and support offices in over 30 countries Renold Couplings can offer service that understands the requirements and challenges of your particular market.

Reliability

Renold rubber in compression couplings are designed and made to the highest of standards delivering a premium product with premium performance. Where hassle free operation, peace of mind and longevity of service count then Renold's rubber in compression couplings are the answer.



RB Flexible Coupling

A great work horse coupling that comes in a variety of configurations including shaft to shaft or shaft to flywheel arrangements. Replaceable rubber blocks enable tuned torsional vibration damping and the fail-safe design, along with Survey Society Type Approval, make it the obvious choice.

Coupling capacity

- Up to 41kNm torque
- Maximum 5,200rpm
- Up to 210mm bore

Applications

- Generator sets
- Pump sets
- Compressors
- Wind turbines
- Metal manufacture
- Bulk handling
- Pulp and paper industry
- General purpose industrial applications
- Marine Propulsion

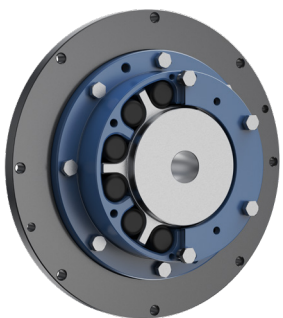

Range options

- ABS, DNV, Lloyds, BV Type Approved
- Shaft to shaft
- Shaft to shaft with increased shaft engagement
- Flywheel to shaft
- Flywheel to shaft with increased shaft engagement

Construction details

- Spheroidal graphite to BS 2789 Grade 420/12
- Separate rubber elements with a choice of grade and hardness with SM70 shore hardness being the standard
- Rubber elements which are totally enclosed and loaded in compression General purpose, cost effective range, which is manufactured in SG iron for torques up to 41kNm

Features and benefits

- Fail-safe design ensures continued operation in the unlikely event of rubber damage
- Tuneable torsional damping delivers low vibratory driveline loads through optimised stiffness characteristics
- Low maintenance, lubrication-free solution requires minimal operational intervention, vastly reducing total cost of ownership
- Severe shock load protection avoids driveline failure in transient over-torque events
- Compensates for axial and radial misalignment between driven and driving equipment
- Pre-compressed rubber blocks provide zero backlash and reduced torque amplifications
- Survey Society Certification provides quality assurance enabling safe integration within a vessel's systems

RB Typical Applications

Generator set



Coupling fitted between the engine and alternator.

Pump sets

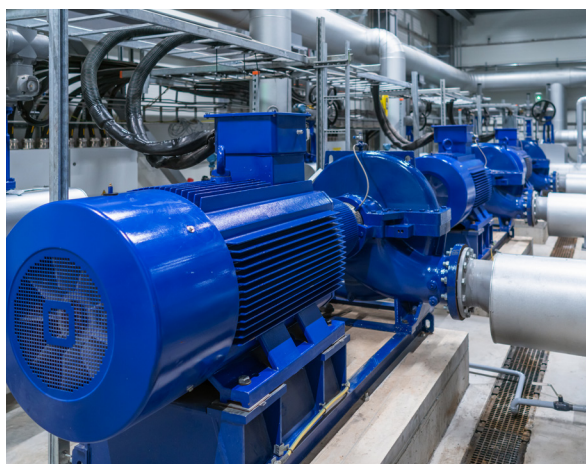

Coupling fitted between diesel engine and centrifugal pump.

Steel mills



Steel mills. Couplings fitted on 35 tonne overhead crane, and on table roller drives.

Industrial fans



Couplings fitted to table roller drives on rolling mills and furnace discharge tables.

RB Shaft to Shaft

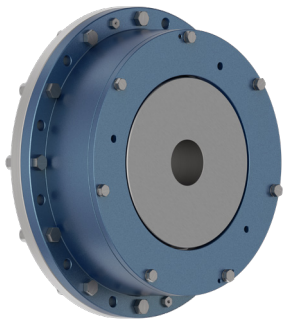

Rigid half/flex half

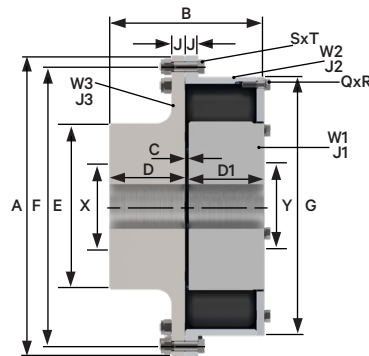

Features and benefits

- Can accommodate a wide range of shaft diameters
- Easy disconnection of the outer member and driving flange
- Coupling available with limited end float
- Allows the optimum coupling to be selected
- Allows the driving and driven machines to be disconnected
- Provides axial location for armatures with axial float

Dimensions, weight, inertia and alignment

Coupling size		0.12	0.2	0.24	0.37	0.73	1.15	2.15	3.86	5.5	
Dimensions (mm)	A	200.0	222.2	238.1	260.3	308.0	358.8	466.7	508.0	571.5	
	B	104.8	111.2	123.8	136.5	174.6	193.7	233.4	260.4	285.8	
	C	3.2	3.2	3.2	3.2	3.2	3.2	4.8	6.4	6.4	
	D	50.8	54.0	60.3	66.7	85.7	95.2	114.3	127.0	139.7	
	D1	50.8	54.0	60.3	66.7	85.7	95.2	114.3	127.0	139.7	
	E	79.4	95.2	101.6	120.6	152.4	184.1	222.2	279.4	330.2	
	F	177.8	200.0	212.7	235.0	279.4	323.8	438.15	469.9	542.92	
	G	156.5	178	186.5	210	251	295	362	435	501.5	
	J	12.7	14.3	15.9	17.5	19.0	19.0	19.0	22.2	25.4	
	Q	5	6	6	6	6	6	6	7	8	
	R	M8	M8	M8	M10	M10	M12	M12	M12	M12	M12
	S	6	6	6	8	8	10	16	12	12	
	T	M8	M8	M10	M10	M12	M12	M12	M12	M16	M16
Rubber elements	MAX.X	50	60	65	80	95	115	140	170	210	
	MAX.Y	55	70	75	85	95	115	140	170	210	
	MIN. X & Y	30	35	40	40	55	55	70	80	90	
Maximum Speed [rpm] (1)	Per cavity	1	1	1	1	1	1	1	1	1	
	Per coupling	10	12	12	12	12	12	12	14	16	
Weight (3) (kg)	W1	2.82	4.04	5.29	7.49	12.82	23.39	35.88	62.81	102.09	
	W2	4.00	5.05	6.38	8.14	13.29	18.41	33.98	43.87	59.00	
	W3	4.06	5.82	7.42	10.44	18.03	27.37	47.43	75.39	113.32	
Inertia (3) (kg m ²)	J1	0.0044	0.0084	0.0131	0.0233	0.0563	0.1399	0.3227	0.8489	1.9633	
	J2	0.0232	0.0375	0.0546	0.0887	0.20	0.3674	1.1035	1.9161	3.4391	
	J3	0.0153	0.027	0.0396	0.0644	0.1475	0.2862	0.7998	1.512	2.9796	

Allowable misalignment (2)

Radial (mm)	0.75	0.75	0.75	0.75	1.0	1.5	1.5	1.5	1.5
Axial (mm)	1.5	1.5	1.5	1.5	1.5	1.5	2.0	3.0	3.0
Conical (degree)	0.5	0.5	0.5	0.5	0.5	0.5	0.5	0.5	0.5

(1) For operation above 80% of the declared maximum coupling speed, it is recommended that the coupling is dynamically balanced.

(2) Installations should be initially aligned as accurately as possible. In order to allow for deterioration in alignment overtime, it is recommended that initial alignment should not exceed 25% of the above noted data. The forces on the driving and driven machinery should be calculated to ensure that these do not exceed the manufacturers allowables.

(3) Weights and inertias are based on the minimum bore size.

RB Shaft to Shaft with Increase Shaft Engagement

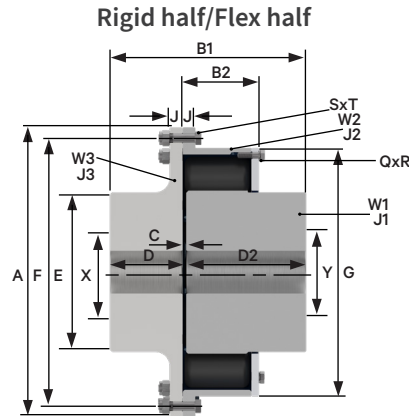
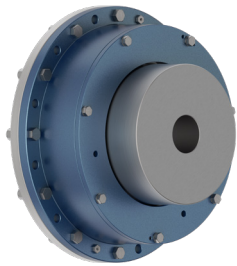

Features and benefits

- Long Boss Inner Member
- Allows small diameter long length shafts to be used
- Reduces key stress
- Allows increased distances between shaft ends
- Full shaft engagement avoids the need for spacer collars

Dimensions, weight, inertia and alignment

Coupling size		0.12	0.2	0.24	0.37	0.73	1.15	2.15	3.86	5.5	
Dimensions (mm)	A	200.0	222.2	238.1	260.3	308.0	358.8	466.7	508.0	571.5	
	B1	139.0	152.2	173.5	189.9	233.9	268.4	309.1	343.4	386.1	
	B2	54.0	57.2	63.5	69.8	88.9	98.4	119.0	133.4	146.0	
	C	3.2	3.2	3.2	3.2	3.2	3.2	4.8	6.4	6.4	
	D	50.8	54.0	60.3	66.7	85.7	95.2	114.3	127.0	139.7	
	D2	85	95	110	120	145	170	190	210	240	
	E	79.4	95.2	101.6	120.6	152.4	184.1	222.2	279.4	330.2	
	F	177.8	200.0	212.7	235.0	279.4	323.8	438.15	469.9	542.92	
	G	156.5	178	186.5	210	251	295	362	435	501.5	
	J	12.7	14.3	15.9	17.5	19.0	19.0	19.0	22.2	25.4	
	Q	5	6	6	6	6	6	6	7	8	
	R	M8	M8	M8	M10	M10	M12	M12	M12	M12	M12
	S	6	6	6	8	8	10	16	12	12	
	T	M8	M8	M10	M10	M12	M12	M12	M16	M16	
	MAX. X	50	60	65	80	95	115	140	170	210	
MAX. Y	55	70	75	85	95	115	140	170	210		
MIN. X&Y	30	35	40	40	55	55	70	80	90		
Rubber elements	Per cavity	1	1	1	1	1	1	1	1	1	
	Per coupling	10	12	12	12	12	12	12	14	16	
Maximum Speed [rpm] (1)		5250	4725	4410	4035	3410	2925	2250	2070	1820	
Weight (3) (kg)	W1	4.21	6.42	8.67	11.85	19.43	35.28	53.81	95.50	162.79	
	W2	4.0	5.05	6.38	8.14	13.29	18.41	33.98	43.87	59.0	
	W3	4.06	5.82	7.42	10.44	18.03	27.37	47.43	75.39	113.32	
Inertia (3) (kg m ²)	J1	0.0059	0.0121	0.0193	0.0326	0.0770	0.1896	0.4347	1.1833	2.8953	
	J2	0.0232	0.0375	0.0546	0.0887	0.2000	0.3674	1.1035	1.9161	3.4391	
	J3	0.0153	0.0270	0.0396	0.0644	0.1475	0.2862	0.7998	1.5120	2.9796	
Allowable misalignment (2)											
Radial (mm)		0.75	0.75	0.75	0.75	1.0	1.5	1.5	1.5	1.5	
Axial (mm)		1.5	1.5	1.5	1.5	1.5	1.5	1.5	3.0	3.0	
Conical (degree)		0.5	0.5	0.5	0.5	0.5	0.5	0.5	0.5	0.5	

(1) For operation above 80% of the declared maximum coupling speed, it is recommended that the coupling is dynamically balanced.

(2) Installations should be initially aligned as accurately as possible. In order to allow for deterioration in alignment overtime, it is recommended that initial alignment should not exceed 25% of the above noted data. The forces on the driving and driven machinery should be calculated to ensure that these do not exceed the manufacturers allowables.

(3) Weights and inertias are based on the minimum bore size.

RB Standard SAE Flywheel to Shaft

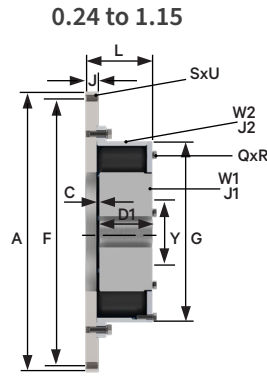
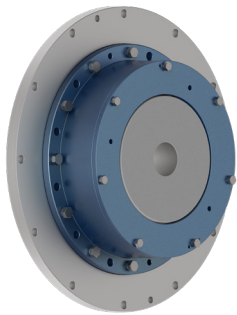

Features and benefits

- Wide range of adaptor plates
- Choice of rubber compound and hardness
- Short axial length
- Allows the coupling to be adapted to suit most engine flywheels
- Allows control of the torsional vibration system
- Allows the coupling to fit in bell housed applications

Dimensions, weight, inertia and alignment

Coupling size	0.24		0.37		0.73		1.15		
	SAE 10	SAE 11.5	SAE 11.5	SAE 14	SAE 11.5	SAE 14	SAE 14	SAE 18	
Dimensions (mm)	A	314.3	352.4	352.4	466.7	352.4	466.7	466.7	571.5
	C	3.2	3.2	3.2	3.2	3.2	3.2	3.2	3.2
	D1	60.3	60.3	66.7	66.7	85.7	85.7	95.2	95.2
	F	295.27	333.38	333.38	438.15	333.38	438.15	438.15	542.92
	G	186.5	186.5	210	210	251	251	295	295
	J	20	20	20	20	20	20	20	28
	L	79.5	79.5	85.8	85.8	104.9	104.9	114.4	122.4
	O	6	6	6	6	6	6	6	6
	R	M8	M8	M10	M10	M10	M10	M12	M12
	S	8	8	8	8	8	8	8	6
	U	10.5	10.5	10.5	13.5	10.5	13.5	13.5	16.7
	MAX. Y	75	75	85	85	95	95	115	115
	MIN. Y	40	40	40	40	55	55	55	55
Rubber elements	Per cavity	1	1	1	1	1	1	1	1
	Per coupling	12	12	12	12	12	12	12	12
Maximum speed (rpm) (1)		3710	3305	3305	2500	3310	2500	2500	2040
Weight (3) (kg)	W1	5.29	5.29	7.49	7.49	12.82	12.82	23.39	23.39
	W2	15.71	17.1	19.96	28.76	24.01	35.31	39.03	61.0
Inertia (3) (kg m ²)	J1	0.0131	0.0131	0.0233	0.0233	0.0563	0.0563	0.1399	0.1399
	J2	0.1922	0.2546	0.3087	0.7487	0.4000	0.8900	1.0274	2.3974
Allowable misalignment (2)									
Radial (mm)		0.75	0.75	0.75	0.75	1.0	1.0	1.5	1.5
Axial (mm)		1.5	1.5	1.5	1.5	1.5	1.5	1.5	1.5
Conical (degree)		0.5	0.5	0.5	0.5	0.5	0.5	0.5	0.5

(1) For operation above 80% of the declared maximum coupling speed, it is recommended that the coupling is dynamically balanced.

(2) Installations should be initially aligned as accurately as possible. In order to allow for deterioration in alignment overtime, it is recommended that initial alignment should not exceed 25% of the above noted data. The forces on the driving and driven machinery should be calculated to ensure that these do not exceed the manufacturers allowables.

(3) Weights and inertias are based on the minimum bore size.

RB Standard SAE Flywheel to Shaft

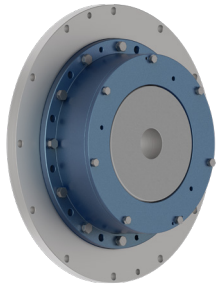

2.15 - 5.5

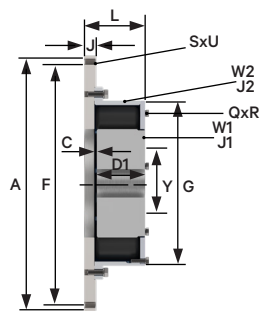

Keep Plate (2.15 SAE 14 and 5.5 SAE 18)

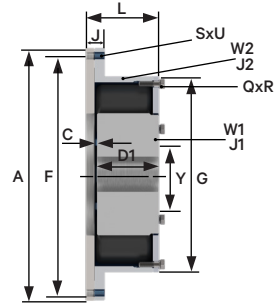

Dimensions, weight, inertia and alignment

Coupling size	2.15			3.86			5.5			
	SAE 14	SAE 18	SAE 21	SAE 18	SAE 21	SAE 24	SAE 18	SAE 21	SAE 24	
Dimensions (mm)	A	466.7	571.5	673.1	571.5	673.1	733.4	571.5	673.1	733.4
	C	4.8	4.8	4.8	6.4	6.4	6.4	6.4	6.4	6.4
	D1	114.3	114.3	114.3	127.0	127.0	127.0	139.7	139.7	139.7
	F	438.15	542.92	641.35	542.92	641.35	692.15	542.92	641.35	692.15
	G	362.0	362.0	362.0	435.0	435.0	435.0	501.5	501.5	501.5
	J	35.0	28.0	28.0	28.0	31.0	31.0	41.4	28.0	31.0
	L	135.05	143.0	143.0	157.35	160.35	160.35	162.05	170.0	173.05
	O	6	6	6	7	7	7	8	8	8
	R	M12	M12	M12	M12	M12	M12	M12	M12	M12
	S	8	6	12	6	12	12	6	12	12
	U	13.2	16.7	16.7	16.7	16.7	22	16.7	16.7	22
	MAX. Y	140	140	140	170	170	170	210	210	210
MIN. Y	70	70	70	80	80	80	90	90	90	
Rubber elements	Per cavity	1	1	1	1	1	1	1	1	1
	Per coupling	12	12	12	14	14	14	16	16	16
Maximum speed (rpm) (1)		2500	2040	1800	2040	1800	1590	2040	1800	1590
Weight (3) (kg)	W1	35.88	35.88	35.88	62.81	62.81	62.81	102.09	102.09	102.09
	W2	50.42	79.17	92.19	86.46	110.35	120.33	79.14	117.21	135.46
Inertia (3) (kg m ²)	J1	0.3227	0.3227	0.3227	0.8489	0.8489	0.8489	1.9633	1.9633	1.9633
	J2	1.6535	3.2935	4.9935	3.9461	6.3661	8.1461	4.5684	7.3291	9.6691
Allowable misalignment (2)										
Radial (mm)		1.5	1.5	1.5	1.5	1.5	1.5	1.5	1.5	1.5
Axial (mm)		2.0	2.0	2.0	3.0	3.0	3.0	3.0	3.0	3.0
Conical (degree)		0.5	0.5	0.5	0.5	0.5	0.5	0.5	0.5	0.5

(1) For operation above 80% of the declared maximum coupling speed, it is recommended that the coupling is dynamically balanced.

(2) Installations should be initially aligned as accurately as possible. In order to allow for deterioration in alignment overtime, it is recommended that initial alignment should not exceed 25% of the above noted data. The forces on the driving and driven machinery should be calculated to ensure that these do not exceed the manufacturers allowables.

(3) Weights and inertias are based on the minimum bore size.

RB Standard SAE Flywheel to Shaft with Increased Shaft Engagement

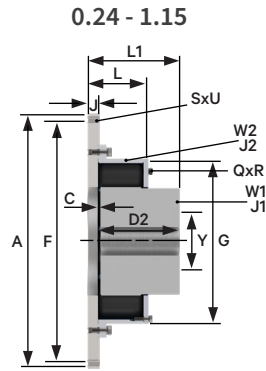
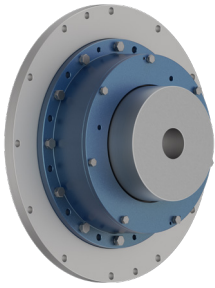

Features and benefits

- Long Boss Inner Members
- Allows small diameter long length shafts to be used
- Reduces key stress
- Allows increased distance between shaft end and flywheel
- Full shaft engagement avoids the need for spacer collars

Dimensions, weight, inertia and alignment

Coupling size	0.24		0.37		0.73		1.15		
	SAE 10	SAE 11.5	SAE 11.5	SAE 14	SAE 11.5	SAE 14	SAE 14	SAE 18	
Dimensions (mm)	A	314.3	352.4	352.4	466.7	352.4	466.7	466.7	571.5
	C	3.2	3.2	3.2	3.2	3.2	3.2	3.2	3.2
	D2	110	110	120	120	145	145	170	170
	F	295.27	333.38	333.38	438.15	333.38	438.15	438.15	542.92
	G	186.5	186.5	210	210	251	251	295	295
	J	20	20	20	20	20	20	20	28
	L	79.5	79.5	85.8	85.8	104.9	104.9	114.4	122.4
	L1	129.2	129.2	139.1	139.1	164.2	164.2	189.2	197.2
	Q	6	6	6	6	6	6	6	6
	R	M8	M8	M10	M10	M10	M10	M12	M12
	S	8	8	8	8	8	8	8	6
	U	10.5	10.5	10.5	13.5	10.5	13.5	13.5	16.7
	MAX. Y	75	75	85	85	95	95	115	115
MIN. Y	40	40	40	40	55	55	55	55	
Rubber elements	Per cavity	1	1	1	1	1	1	1	1
	Per coupling	12	12	12	12	12	12	12	12
Maximum speed (rpm) (1)		3710	3305	3305	2500	3305	2500	2500	2040
Weight (3) (kg)	W1	8.67	8.67	11.85	11.85	19.43	19.43	35.28	35.28
	W2	15.71	17.10	19.96	28.76	24.01	35.31	39.03	61.00
Inertia (3) (kg m ²)	J1	0.0193	0.0193	0.0326	0.0326	0.0770	0.0770	0.1896	0.1896
	J2	0.1922	0.2546	0.3087	0.7487	0.4000	0.8900	1.0274	2.3974
Allowable misalignment (2)									
Radial (mm)		0.75	0.75	0.75	0.75	1.0	1.0	1.5	1.5
Axial (mm)		1.5	1.5	1.5	1.5	1.5	1.5	1.5	1.5
Conical (degree)		0.5	0.5	0.5	0.5	0.5	0.5	0.5	0.5

(1) For operation above 80% of the declared maximum coupling speed, it is recommended that the coupling is dynamically balanced.

(2) Installations should be initially aligned as accurately as possible. In order to allow for deterioration in alignment overtime, it is recommended that initial alignment should not exceed 25% of the above noted data. The forces on the driving and driven machinery should be calculated to ensure that these do not exceed the manufacturers allowables.

(3) Weights and inertias are based on the minimum bore size

RB Standard SAE Flywheel to Shaft with Increased Shaft Engagement

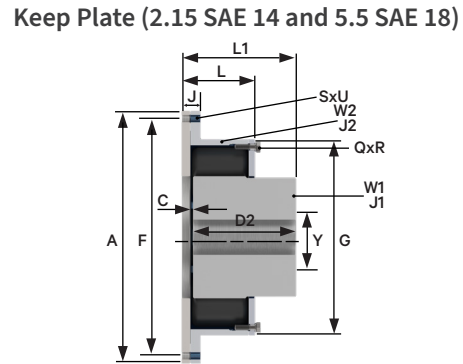
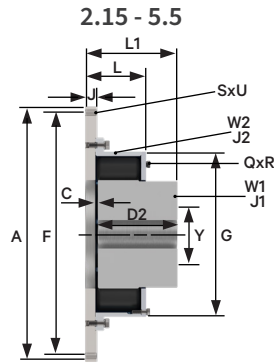
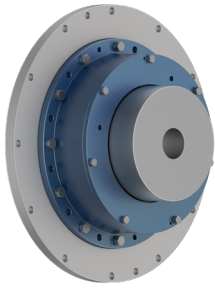

Dimensions, weight, inertia and alignment

Coupling size	2.15			3.86			5.5			
	SAE 14	SAE 18	SAE 21	SAE 18	SAE 21	SAE 24	SAE 18	SAE 21	SAE 24	
Dimensions (mm)	A	466.7	571.5	673.1	571.5	673.1	733.4	571.5	673.1	733.4
	C	4.8	4.8	4.8	6.4	6.4	6.4	6.4	6.4	6.4
	D2	190	190	190	210	210	210	240	240	240
	F	438.15	542.92	641.35	542.92	641.35	692.15	542.92	641.35	692.15
	G	362.0	362.0	362.0	435.0	435.0	435.0	501.5	501.5	501.5
	J	35.0	28.0	28.0	28.0	31.0	31.0	41.4	28.0	31.0
	L	135	143.0	143.0	157.4	160.4	160.4	162.05	170.0	173.0
	L1	210.7	219.7	219.7	240.4	243.4	243.4	262.4	271.3	273.3
	Q	6	6	6	7	7	7	8	8	8
	R	M12	M12	M12	M12	M12	M12	M12	M12	M12
	S	8	6	12	6	12	12	6	12	12
	U	13.5	16.7	16.7	16.7	16.7	22	16.7	16.7	22
	MAX. Y	140	140	140	170	170	170	210	210	210
MIN. Y	70	70	70	80	80	80	90	90	90	
Rubber elements	Per cavity	1	1	1	1	1	1	1	1	
	Per coupling	12	12	12	14	14	14	16	16	
Maximum speed (rpm) (1)		2500	2040	1800	2040	1800	1590	2040	1800	1590
Weight (3) (kg)	W1	53.81	53.81	53.81	95.50	95.50	95.50	162.79	162.79	162.79
	W2	50.42	79.17	92.19	86.46	110.35	120.33	79.14	117.21	135.46
Inertia (3) (kg m ²)	J1	0.4347	0.4347	0.4347	1.1833	1.1833	1.1833	2.8953	2.8953	2.8953
	J2	1.6535	3.2935	4.9935	3.9461	6.4661	8.1461	4.5684	7.3291	9.6691
Allowable misalignment (2)										
Radial (mm)		1.5	1.5	1.5	1.5	1.5	1.5	1.5	1.5	1.5
Axial (mm)		2.0	2.0	2.0	3.0	3.0	3.0	3.0	3.0	3.0
Conical (degree)		0.5	0.5	0.5	0.5	0.5	0.5	0.5	0.5	0.5

(1) For operation above 80% of the declared maximum coupling speed, it is recommended that the coupling is dynamically balanced.

(2) Installations should be initially aligned as accurately as possible. In order to allow for deterioration in alignment overtime, it is recommended that initial alignment should not exceed 25% of the above noted data. The forces on the driving and driven machinery should be calculated to ensure that these do not exceed the manufacturers allowables.

(3) Weights and inertias are based on the minimum bore size.

RB Technical Data

1.1 Torque Capacity - Diesel Engine Drives

The RB Coupling is selected on the “Nominal Torque T_{KN} ” without service factors for Diesel Drive applications.

The full torque capacity of the coupling for transient vibration whilst passing through major criticals on run up, is published as the maximum torque.
($T_{KMAX} = 3 \times T_{KN}$).

There is additional torque capacity built within the coupling for short circuit and shock torques, which is $3 \times T_{KMAX}$. The published “Vibratory Torque T_{KW} ”, relates to the amplitude of the permissible torque fluctuation. The vibratory torque values shown in the technical data are at the frequency of 10Hz. The allowable vibratory torque at higher or lower frequencies $f_e = T_{KW}$.

The measure used for acceptability of the coupling under vibratory torque, is published as “Allowable dissipated heat at ambient temperature 30 °C”.

1.2 Industrial Drives

For industrial Electrical Motor Applications refer to the “Selection Procedures”, and base the selection on T_{KMAX} with the appropriate service factors.

The service factors used in the “Selection Procedures” are based upon 50 years’ experience of drives and their shock frequency/amplitude. The stated T_{KMAX} quoted should not be exceeded by design, without reference to Renold Hi-Tec Couplings.

Care should be taken in the design of couplings with shaft brakes, to ensure that coupling torques are not increased by severe deceleration.

2.0 Stiffness Properties

The Renold Hi-Tec Coupling remains fully flexible under all torque conditions. The RB series is a non-bonded type operating with the Rubber-in-Compression principle.

2.1 Axial Stiffness

When subject to axial misalignment, the coupling will have an axial resistance which gradually reduces due to the effect of vibratory torque.

Given sufficient axial force, as shown in the technical data, the coupling will slip to its new position immediately.

2.2 Radial Stiffness

The radial stiffness of the coupling is torque dependent, and is as shown in the technical data.

2.3 Torsional Stiffness

The torsional stiffness of the coupling is dependent upon applied torque (see technical data) and temperature.

2.3 Prediction of the System Torsional Vibration Characteristics

An adequate prediction of the system’s torsional vibration characteristics, can be made by the following method:

- 2.4.1 Use the torsional stiffness as shown in the technical data, which is based upon data measured at a 30 °C ambient temperature (C_{Tdyn}).
- 2.4.2 Repeat the calculation 2.4.1, but using the maximum temperature correction factor S_{t100} , and dynamic magnifier correction factor, M_{100} , for the selected rubber. Use tables on page 13 to adjust values for both torsional stiffness and dynamic magnifier.
ie. $C_{t100} = C_{Tdyn} \times S_{t100}$
- 2.4.3 Review calculations 2.4.1 and 2.4.2 and if the speed range is clear of criticals which do not exceed the allowable heat dissipation value as published in the catalogue, then the coupling is considered suitable for the application with respect to the torsional vibration characteristics. If there is a critical in the speed range, then actual temperature of the coupling will need to be calculated at this speed

RB Technical Data

Rubber grade	Temp _{max} °C	S _t
Si70	200	S _{t200} = 0.48
SM60	100	S _{t100} = 0.75
SM70	100	S _{t100} = 0.63
SM80	100	S _{t100} = 0.58

SM70 is considered "standard"

Rubber grade	Dynamic magnifier at 30°C (M ₃₀)	Dynamic magnifier at 100°C (M ₁₀₀)
SM60	8	10.7
SM70	6	9.5
SM80	4	6.9
Si70	7.5	M ₂₀₀ = 15.63

SM70 is considered "standard"

2.5 Prediction of the Actual Coupling Temperature and Torsional Stiffness

- 2.5.1 Use the torsional stiffness as published in the catalogue, this is based upon data measured at 30 °C and the dynamic magnifier at 30 °C. (M₃₀).
- 2.5.2 Compare the synthesis value of the calculated heat load in the coupling (P_K) at the speed of interest, to the "Allowable Heat Dissipation" (P_{KW})

The coupling temperature rise

$$^{\circ}\text{C} = \text{Temp}_{\text{coup}} = \left(\frac{P_K}{P_{KW}} \right) \times 70$$

The coupling temperature = ϑ

$$\vartheta = \text{Temp}_{\text{coup}} + \text{Ambient Temp.}$$

- 2.5.3 Calculate the temperature correction factor, S_t, from 2.6 (if the coupling temperature > 100 °C, then use S_{t100}). Calculate the dynamic Magnifier as per 2.7. Repeat the calculation with the new value of coupling stiffness and dynamic magnifier.
- 2.5.4 Calculate the coupling temperature as per 2.5. Repeat calculation until the coupling temperature agrees with the correction factors for torsional stiffness and dynamic magnifier used in the calculation.

2.6 Temperature correction factor

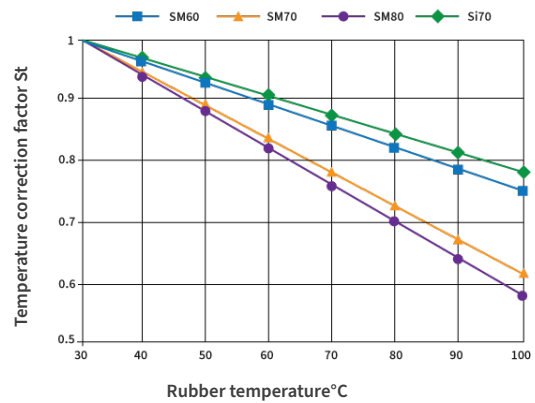

2.7 Dynamic magnifier correction factor

The Dynamic Magnifier of the rubber is subject to temperature variation in the same way as the torsional stiffness.

$$M_T = \frac{M_{30}}{S_t} \quad \Psi_T = \Psi_{30} \times S_t$$

Rubber grade	Dynamic magnifier (M ₃₀)	Relative damping Ψ_{30}
SM60	8	0.78
SM70	6	1.05
SM80	4	1.57
Si70	7.5	0.83

SM70 is considered "standard"

RB Technical Data

Coupling size		0.12	0.2	0.24	0.37	0.73	1.15	2.15	3.86	5.5
Nominal torque T _{KN} (kNm)		0.314	0.483	0.57	0.879	1.73	2.731	5.115	9.159	13.05
Maximum torque T _{Kmax} (kNm)		0.925	1.425	1.72	2.635	5.35	8.1	15.303	27.4	41.0
Vibratory torque T _{KW} (kNm)		0.122	0.188	0.222	0.342	0.672	1.062	1.989	3.561	5.075
Allowable dissipated heat at amb. temp 30°C P _{KW} (W) P _{KW}	Si70	252	315	346	392	513	575	710	926	1144
	SM60	90	112	125	140	185	204	246	336	426
	SM70	98	123	138	155	204	224	270	369	465
	SM80	100	138	154	173	228	250	302	410	520
Dynamic Torsional Stiffness C _{Tdyn} (MNm/rad)										
0.25 nominal torque	Si70	0.004	0.006	0.006	0.010	0.021	0.031	0.060	0.091	0.119
	SM60	0.007	0.009	0.010	0.016	0.032	0.049	0.093	0.142	0.186
	SM70	0.011	0.014	0.017	0.026	0.052	0.079	0.150	0.230	0.300
	SM80	0.016	0.021	0.025	0.039	0.079	0.119	0.225	0.346	0.453
0.50 nominal torque	Si70	0.013	0.017	0.020	0.030	0.062	0.093	0.176	0.271	0.355
	SM60	0.016	0.021	0.025	0.038	0.078	0.118	0.223	0.343	0.449
	SM70	0.022	0.028	0.034	0.052	0.105	0.159	0.300	0.460	0.602
	SM80	0.026	0.033	0.040	0.062	0.125	0.189	0.358	0.549	0.719
0.75 nominal torque	Si70	0.030	0.038	0.046	0.070	0.142	0.215	0.407	0.625	0.818
	SM60	0.035	0.045	0.054	0.082	0.167	0.253	0.479	0.735	0.962
	SM70	0.043	0.055	0.066	0.101	0.205	0.310	0.586	0.900	1.178
	SM80	0.049	0.063	0.076	0.117	0.238	0.360	0.680	1.043	1.366
1.0 nominal torque	Si70	0.050	0.064	0.077	0.118	0.240	0.363	0.686	1.053	1.379
	SM60	0.057	0.073	0.088	0.134	0.273	0.413	0.780	1.197	1.567
	SM70	0.066	0.085	0.103	0.157	0.319	0.483	0.912	1.400	1.833
	SM80	0.078	0.100	0.121	0.185	0.377	0.570	1.077	1.653	2.164
Radial stiffness (N/mm) at no load	Si70	1153	1424	1622	1801	2391	2610	3243	4226	5343
	SM60	1020	1260	1435	1594	2116	2310	2870	3740	4728
	SM70	1255	1550	1765	1962	2586	2845	3530	4600	5810
	SM80	1728	2135	2430	2700	3654	3915	4860	6330	8008
Radial stiffness (N/mm) at T _{KN}	Si70	2096	2594	2948	3335	4335	4754	5904	7690	9726
	SM60	2046	2536	2880	3207	4250	4650	5780	7520	9510
	SM70	2134	2638	3000	3435	4396	4835	6000	7820	9890
	SM80	2310	2855	3250	3610	4885	5235	6500	8465	10700
Axial stiffness (N/mm) at no load	Si70	788	962	1077	1225	1589	1780	2202	2886	3663
	SM60	1030	1250	1400	1600	2095	2310	2850	3700	4700
	SM70	1100	1350	1510	1710	2200	2500	3100	4100	5200
	SM80	2940	3690	4060	4620	6060	6700	8220	10760	13580
Max axial force (1) at T _{KN} (N)	Si70	540	675	750	850	1100	1230	1500	1950	2500
	SM60	1080	1350	1500	1700	2200	2460	3000	3900	5000
	SM70	1150	1440	1600	1800	2360	2600	3200	4100	5300
	SM80	1300	1600	1760	2000	2600	2900	3500	4600	5800

NB. SM70 is supplied as standard rubber grade with options of rubber grades SM60 or SM80, if these are considered a better solution to a dynamic application problem. It should be noted that for operation above 80% of the declared maximum coupling speed, the coupling should be dynamically balanced.

(1) The Renold Hi-Tec Coupling will “slip” axially when the maximum axial force is reached.

Design Variations

The RB Coupling can be adapted to meet customer requirements, as can be seen from some of the design variations shown below. For a more comprehensive list, contact Renold Hi-Tec.

Spacer Coupling

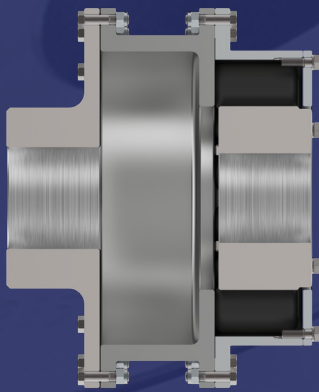

Used to increase distance between shaft ends and allow easy access to driven and driving machines.

Cardan Shaft Coupling

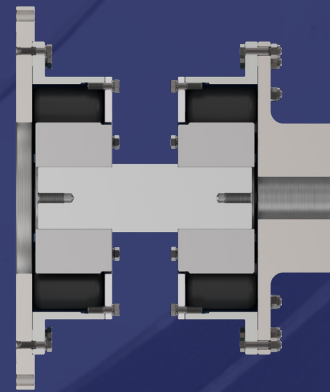

Used to increase the distance between shaft ends and give a higher misalignment capability.

Coupling with Long Boss Inner Member

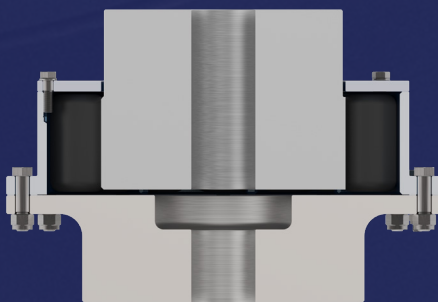

Coupling with long boss inner member and large boss driving flange for use on vertical applications.

Brake Drum Coupling

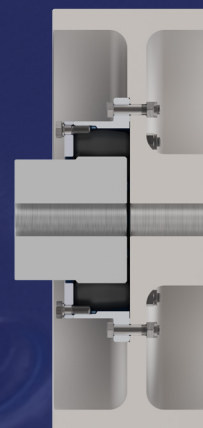

Coupling with brake drum for use on cranes, fans and conveyor drives, (brake disk couplings are available).

Global services

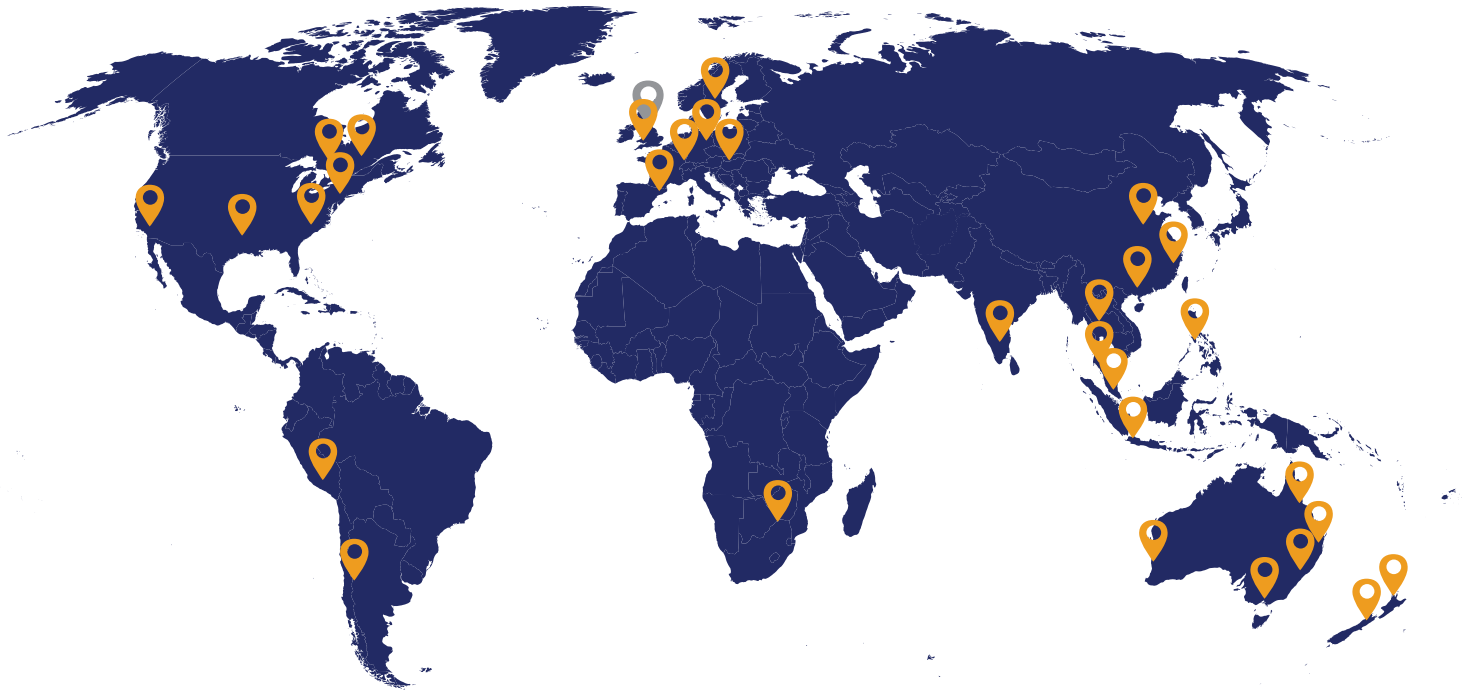

 **Head office**  **Renold locations**



Internal support

Sales team embedded in the manufacturing site with unrivalled product knowledge



Large engineering team

Our team can design a quality coupling to match your exact requirements

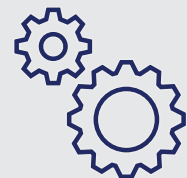

Manufacturing facility

Designed and manufactured in house by Renold; giving ultimate control on our solutions

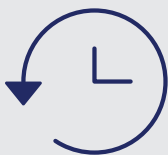

History and Longevity

Manufacturing in the UK for over 100 years and commitment in our facilities for the long term, we are here to stay



Excellent Communication

From an accessible sales team, weekly order updates and a global sales network we make it easy to communicate



Record investment

Heavy investment in our business; spending millions of pounds upgrading CNC equipment, metrology arms and the newest software and test rigs

Get in touch

For your local Renold
sales and service location

+44 (0) 29 2079 2737



cardiff.sales@renold.com



www.renold.com



Wentloog Corporate Park
Newlands Road, Cardiff
CF3 2EU



LRQA
CERTIFIED

ISO 9001

LRQA
CERTIFIED

ISO 45001

LRQA
CERTIFIED

ISO 14001